



SAFETY ALERT

DATE: August 15, 2002

SUBJECT: **SECOND NOTICE: Proper use of Anco Lock Nuts**

SERIAL NUMBERS: 002 and Up

DISCUSSION: Anco lock nuts (See attachment Figure 78.1) are a galvanized construction and the thread profile is made to match with galvanized threads. These threads are not compatible with standard NC threads. These components are currently used on some torque reaction and rig interface assemblies.

RECOMMENDATION:

1. Use Anco nuts only with proper galvanized rod or bolt.
2. Use Stover locknuts with B7 UNC threaded rod or bolt.
3. When installing any locknut at least three threads must be extended past the outer most locking mechanism (locking tab in case of Anco). If this is not possible, replace the threaded rod or bolt with one of sufficient length and material.
4. **Anco nuts are for one time use only. Replace with new nuts if removed.**

INFORMATION:

For further information contact:

Field Operations Manager
Canrig Drilling Technology Ltd.
14703 FM 1488
Magnolia, Texas 77354
Phone: 281.259.8887
Fax: 281.259.8158

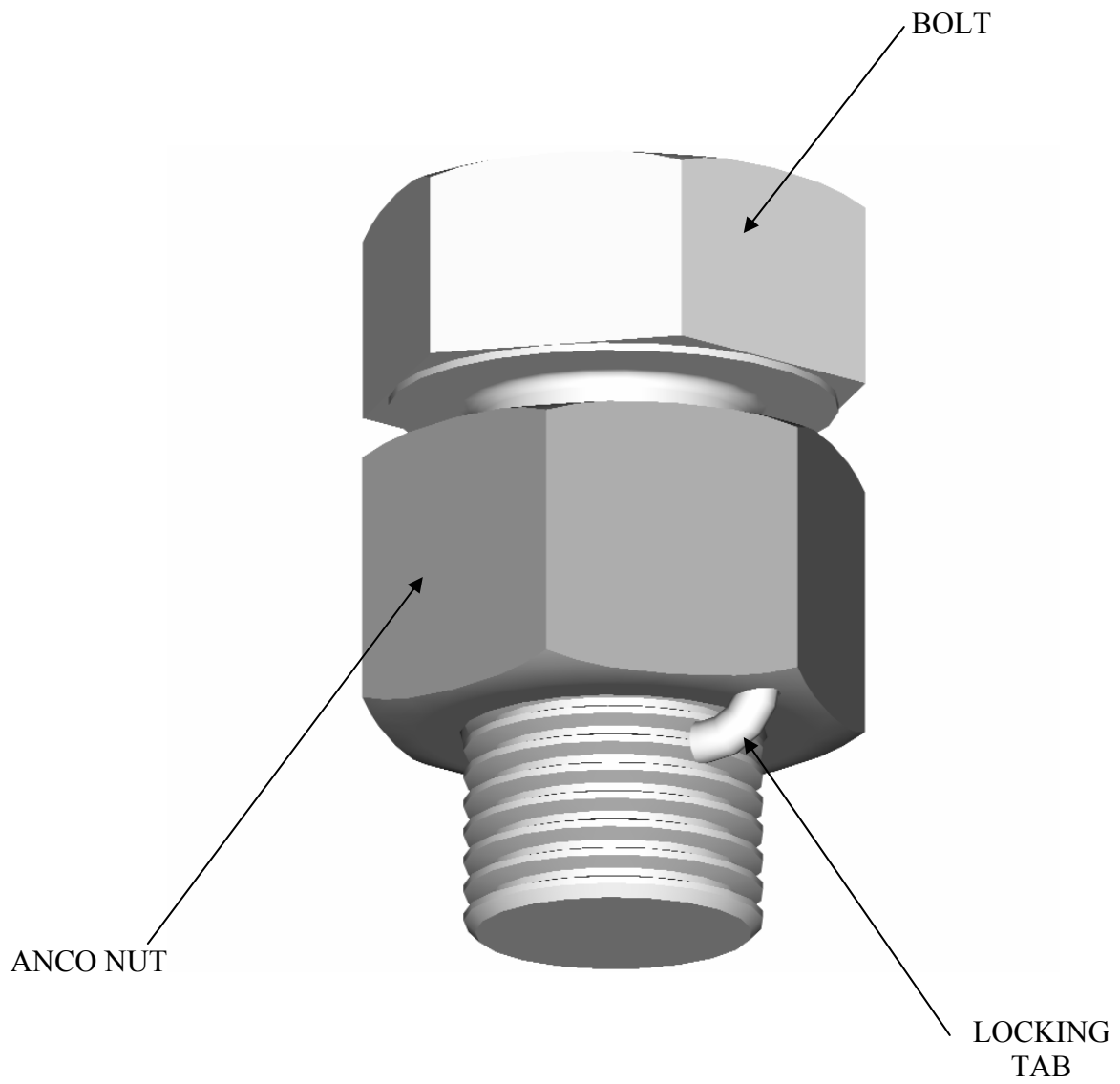

Figure 78.1